

Sensor head and occupancy detection performance

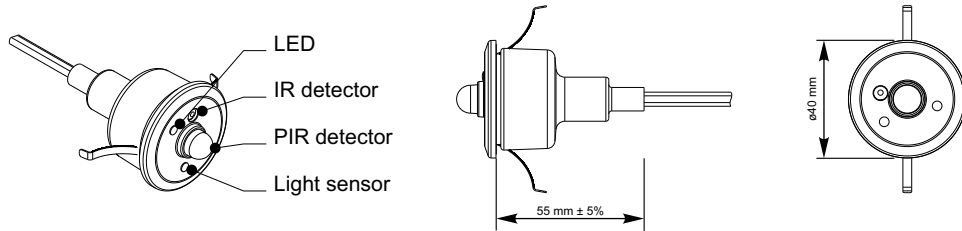

The sensor head fits into a Ø35MM hole, with clips which can grip ceiling panels down to 1.5mm thick. The sensor head has a rectangular occupancy detection range broadly 9m x 7m at a ceiling height of 2.5m (Longest length of detection aligning with the spring clips). As the ceiling height increases so will the overall detection area but sensitivity to small movements will decrease.

Note: Make sure that the sensor is not adjacent to circulating air, heaters or lamps.

Detection Zone

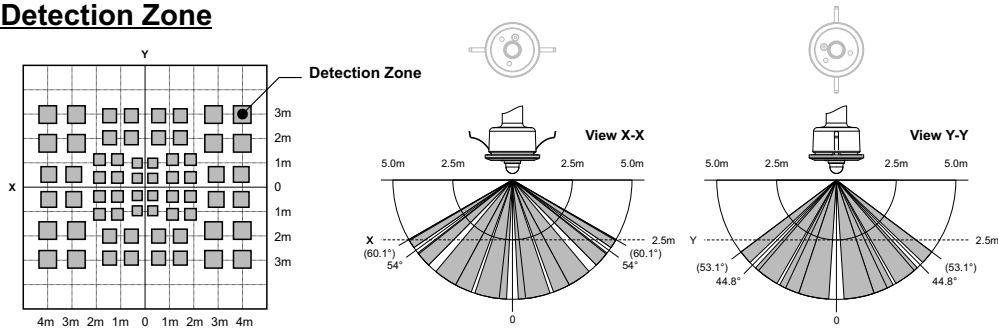

The X-Y cross-sectional diagram shows the detection area. The differences in the detection zone patterns indicate the projections of the 16 lenses with a single focal point. Movement of an object with higher than background temperature, between the detection zones, will be detected.

Note: For safe operation it is advisable to extend occupancy coverage to cover the wall switch. In this way, operating the switch to 'SENSOR' position ensures the lights turn ON.

Supply Voltage :12V DC

Material :White & red PA6 UL94 V-0 rated, Non-halogen

Operating range :-10°C to 40°C

IP Rating :IP20

Compliance :2014/35/EU

:2014/30/EU



flex7 Limited, Ruscombe Business Park, Ruscombe Lane, Twyford, Berkshire RG10 9JW, UK
 Telephone: +44 (0) 20 8580 1066 Fax: +44 (0) 20 8580 1062
 Website: www.flex7.co.uk Email: info@flex7.co.uk
 Leaflet reference number: 22/125 issue 1 13/01/2026



FZH/PIR/LS/IP67 Light sensing & occupancy sensor head

Working in conjunction with the ZoneLite control unit, the FZH/PIR/LS/IP67 sensor head provides additional sensory data from the room. This takes the form of occupancy, light level and received instructions from a remote control such as the FZL/RC and FRC/USER remote control.

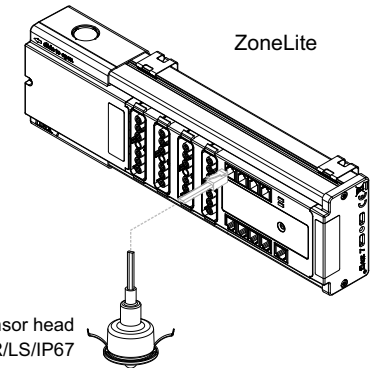

Considerations before installation

The FZH/PIR/LS/IP67 sensor head detects both occupancy and light level. However, conditions for optimum light sensing should always have priority over those for occupancy coverage. To achieve effective light level control, select only an area where the daylight contribution, though changeable, is significant and remains consistent across the area.

✗ As lamp output across the circuit must be common, it is not possible to provide the 'optimal' luminosity for all areas when some receive more daylight than others.

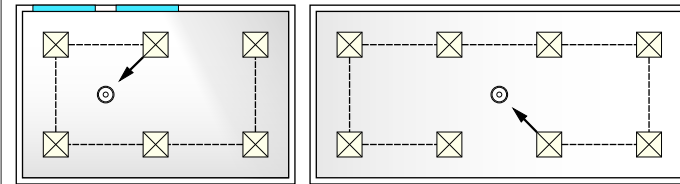

✓ Try to split into zones where the changes in daylight are reasonably consistent. Darker areas may then be controlled via alternative means such as on/off without consideration to light level. You may even consider sufficient natural light reaches

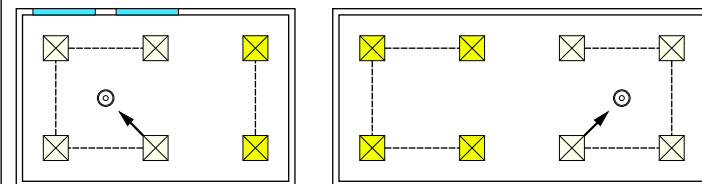

these areas to justify a second light level sensing circuit.

Note: Make sure that the sensor is not adjacent to circulating air, heaters or lamps. Always fit the sensor head as close as possible to the centre of the group of lights under its control.

Setting Up

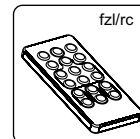

Setup Remote Control - FZL/RC

The sensor can only be setup by using an FZL/RC remote control - ordered separately. Full instructions for setting up the sensor are supplied in the ZoneLite booklet.