

The **fnc4000(D,X or A)/E** are all control devices that can plug directly into any of the range of connection units or a 7-pole single socket outlet. Working with a switch or together with a plug-in sensor head, the device will control the connected mains rated luminaires ON/OFF, DIM up or down and will be able to carry out an emergency test. Note that any connected switch or sensor head will be operating at ELV.

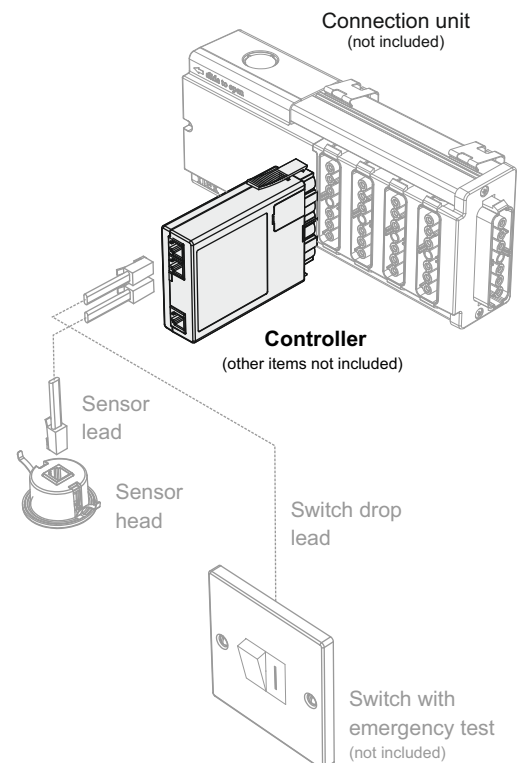

Three products are available:  
**fnc4000D/E** : DSI digital dimmable ballasts.  
**fnc4000X/E** : DALI digital dimmable ballasts.  
**fnc4000A/E** : Analogue ballasts 0-10V.

Please ensure the correct product is selected for the type of ballast being used as incorrect connection may damage the controller.

**This product should only be installed by a qualified electrician.**

Configuring the **fnc4000(D,X or A)/E** controller

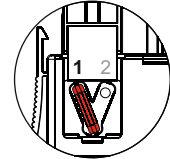
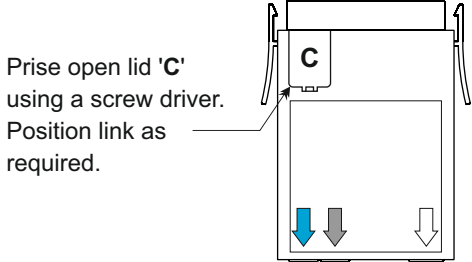

**Link in position 1**  
 Lights can remain ON during an emergency test. Wire connection unit as shown on the back page.

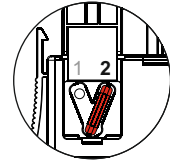

**Link in position 2**  
 Lights will switch OFF during an emergency test. Wire connection unit as shown on the back page.

<b>Supply Voltage</b> :Nominal 230V~ 50Hz	<b>Peak Inrush</b> :120A
<b>Type</b> :Class 2	<b>IP Rating</b> :IP20
<b>Material</b> :PA6 UL94 V-0 rated, Non-halogen	<b>Compliance</b> :2014/35/EU
<b>Operating range</b> :-10°C to 40°C	:2014/30/EU
<b>Total Load</b> :10A	<b>Max No. DALI</b> :up to 25 drivers
<b>Switched Load</b> :6A	

## Using a fnc4000(D,X or A)/E controller with sensor head & override switch

\* Refer to leaflet *Networking Sensors*, leaflet number 17/245.

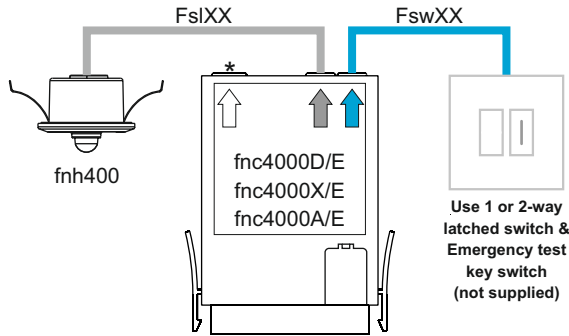

### See table below for other switching options

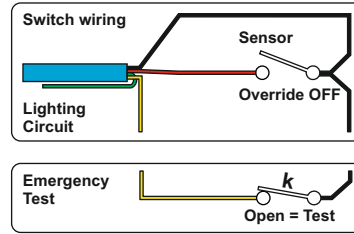

Cut back & insulate unwanted cores.

Override OFF only with emergency test

### Operation:

#### Switch control:

Override OFF - turns the lights OFF (takes priority over sensing).

#### Emergency Test:

Operate key switch to carry out an emergency test.

**Occupancy detection:** Provided the wall switch is in the 'Sensor' position, the lights will switch ON whenever there is occupancy detected by the sensor head. When occupancy is no longer detected, lights will switch OFF after a pre-selected time-out period.

**Daylight linking:** When lights are ON due to occupancy their light output will adjust to compensate for any changes in ambient light in order to maintain a constant light level under the sensor head - the *target level*.

#### Note:

For safe operation it is advisable that occupancy coverage extends to cover the wall switch. In this way, operating the switch to 'SENSOR' position ensures the lights turn ON.

#### Note:

If your room requires 2-way switching, a special 'Y' connector is available to enable two switch drop leads to be connected. (Part No. fsy/2e/2 - OFF control from 2 x 2-way switches)

### Other switching options incorporating override ON

#### Note:

You may not be able to claim enhanced capital allowances under the Carbon Trust scheme if you incorporate local 'override ON' switches in your occupancy sensor scheme.

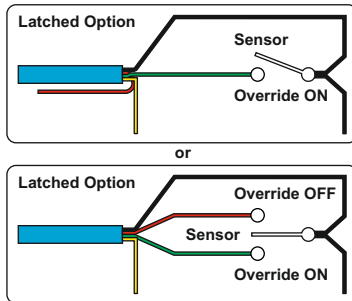

### Emergency test

For an emergency test circuit, wire the yellow and black wire in the key switch as shown on the previous diagrams.

**Note:** Alternative operational options not necessarily shown above are available using the frc/set setup remote control. Full instructions for setting up the sensor are supplied with the sensor head and the frc/set remote control - both ordered separately.

## Circuit diagram for the fnc4000(D,X or A)/E controller

